

Ventris VEV100-1 Internal Valve

The Ventris Internal Valve is designed with an independent external exhaust, which isolates the valve exhaust from the rest of the system. This valve is compatible with diesel, biodiesel, gasoline, ethanol and methanol.

The Viton® GFLT and PTFE-encapsulated seals provide ultimate product compatibility. This valve features an integrated air inlet that allows the unit to close if it becomes sheared in the event of an accident. It incorporates a frangible shear groove per 49CFR178.345-8 tested per TTMA RP 84. A factory-installed fusible plug that will melt at a temperature of 212°F (100°C) allowing the valve to deplete air pressure. Also included is a mechanical jack screw for manual operation in the event of air-pressure loss.

Operating Pressure Requirements: Minimum of 40 psi (2.76 bar) operating line pressure.

Features and Benefits

- Designed for petroleum applications
- Compatible with DN100 connection
- Integrated external exhaust
- Shear Groove to prevent spillage in case of accident
- Fusible plug with a melting point of 165°F (74°C) to deplete air pressure
- Manually openable in case of emergency
- Stainless Steel Filter/ strainer screen

Specifications

- **Materials:**
 - Aluminum
 - Stainless Steel shaft
 - Viton / Buna seals
- **Maximum Working Pressure:** 150 psi (10.34 bar)
- **Weight:** 10.14 lbs. (4.6 kg)
- **Minimum Operating Air Pressure:** 40 psi (2.06 bar)
- **Working Temperature:** -40°F (-40°C) to 160°F (70°C)



Ventris Internal Valve
VEV100-1 (Square Flange Euro-100-1 Style)

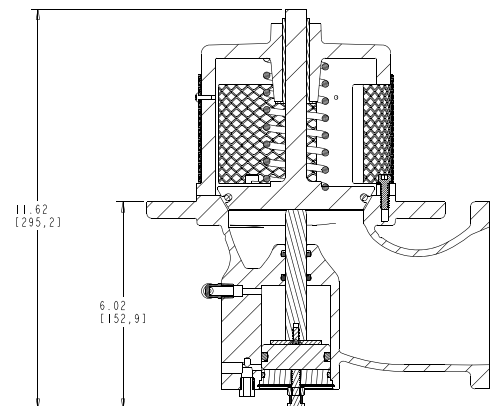
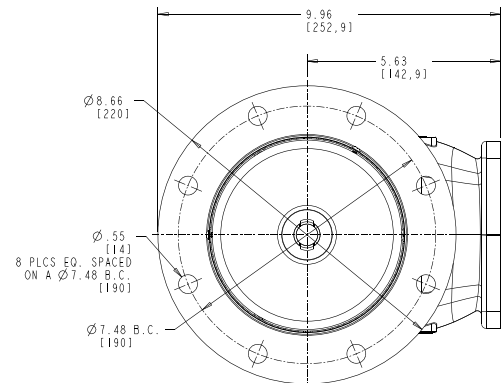

SECTION A-A

