

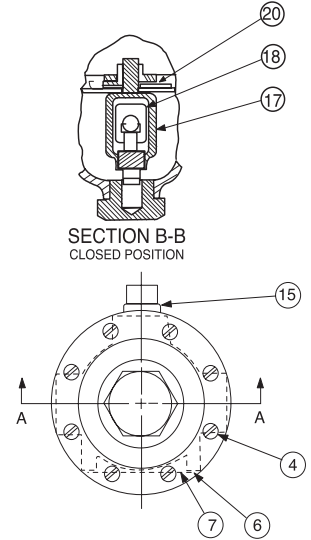

CRD

Pressure Reducing Control

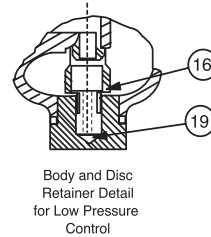
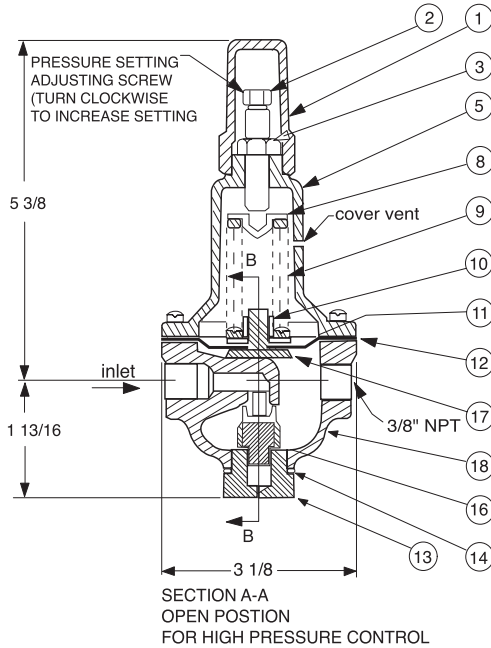

Size (inch)	Stock Number	Adjustment Range	
		psi	Ft of Water
3/8	71943-07A	2 - 6.5	4.5 - 15
3/8	71943-08J	2 - 30	4.5 - 69
3/8	71943-03K	15 - 75	35 - 173
3/8	71943-11C	20 - 105	46 - 242
3/8	71943-04H	30 - 300	69 - 692
Factory Set Pressure		PSI per Turn*	
	2 - 6.5 set @ 3.5 psi	.61	
	2 - 30 set @ 10 psi	3.0	
	15 - 75 set @ 20 psi	9.0	
	20 - 105 set @ 60 psi	12.0	
	30 - 300 set @ 60 psi	27.0	

*Approximate-Final Adjustment should be with a pressure gauge and with flow.

Item	Description	Material	Part Number	List Price
1	Cap	PL	67628J	
2	Adjusting Screw	BRS	7188201D	
3	Jam Nut (3/8-16)	SS	6780106J	
4*	Machine Screw (Fil.Hd.) 8 Req'd	303	6757821B	
5	Cover	BRS	C2544K	
6	Nameplate Screw	SS	67999D	
7	Nameplate	BRS	C0022001G	
8	Spring Guide	302	71881H	
	Spring Guide (20 - 105 psi)	303	205620F	
9	Spring (15-75 psi)	CHR/VAN	71884B	
	Spring (2 - 6.5 psi)	SS	82575C	
	Spring (2 - 30 psi)	SS	81594E	
	Spring (20 - 105 psi)	316	20632101E	
	Spring (30 - 300 psi)	CHR/VAN	71885J	
10	Hex Nut	303	71883D	
11	Diaphragm Washer	302	71891G	
12*	Diaphragm	NBR	C6936D	
13	Plug, Body	BRS	V5653A	
14*	Gasket	Fiber	40174F	
15	Plug	BRS	6766003F	
16*	Disc Retainer Assy. (15 - 75 psi)	BZ/Rub	C5256H	
	Disc Retainer Assy. (2 - 30 psi)	BZ/Rub	C5255K	
	Disc Retainer Assy. (20 - 105 psi)	BZ/Rub	C5256H	
	Disc Retainer Assy. (30 - 300 psi)	BZ/Rub	C5256H	
17	Yoke	VBZ	V6951H	
18	Body & 1/4" Seat Assy	BR/SS	8339702G	
19*	Bucking Spring (2 - 6.5 psi)(2 - 30psi)	302	V0558G	
20	Belleville Washer	STL	7055007E	
*	Repair Kit (No Bucking Spring)	Buna®-N	9170003K	
*	Repair Kit (with Bucking Spring)	Buna®-N	9170002B	

*SUGGESTED REPAIR PARTS

When ordering parts specify:

- All nameplate data
- Item Description
- Item number